

AM PLL Professional Medium-Wave Transmitter



These AM Transmitters operate between 540KHz and 1800KHz in the Medium Waveband (AM Band) and is designed to be reliable and stable.

Two units are available in 1 watt and a 4-watt output version. The 1-watt version is capable of delivering over 1 watt of RMS power into a short length aerial. It can usually deliver 1.5 watts cleanly driven to 100% modulation. The 4-watt version can deliver more than the specified output. (Power drops off at lower frequencies -see spec below for details on the other versions)

The Transmitter circuit design employs a CMOS Phase Locked Loop oscillator circuit for accuracy and ease of frequency selection. A binary code is created by the 8 position DIP switch. It is also very stable and therefore does not drift off frequency. The Phase Lock circuit provides selection in either 9KHz steps for UK/European Union or 10KHz steps for USA. A suitable Crystal is used for either selection and is selected at time of ordering. A

rugged Power MOSFET is also used on the RF output stage, which drives the output toroid and variable tuning capacitor. High voltage rated components are used in the output section.

Audio modulation is series-derived using a pair of Darlington Power Transistors. These are in turn driven by an audio level control chip which allows the transmitter to achieve maximum modulation at all times, whatever the audio source and nominal level is, within reason. (CD player, mixer, PC etc)

It also acts as an audio expander, so low audio levels are increased.

Housed in a Steel box with ABS front and rear panels. Ventilation holes to improve air flow for component cooling. A fan is used on the higher 4-watt output models.



POWER SUPPLY --- IMPORTANT --- PLEASE NOTE

Power is provided from an external plug-top power unit. A transmitter is supplied with a specific power unit, as certain components inside the transmitter are voltage sensitive and could either burn-out or cause damage if the wrong power voltage is applied. Therefore, only use the supplied power unit, otherwise damage may well occur.

It will be evident whether a wrong power unit has been used which in turn causes internal damage!!

The transmitter comes already set up for use, together with a mains power supply and wire aerial.



Setup

1. Insert stripped end of wire into the Aerial terminal and screw into place
2. Hang aerial as vertically as possible at least 30cm away from walls etc
3. Adjust frequency using DIP switches on the rear as per required settings.
4. Connect phono audio cable (L and R) to transmitter and audio source.
5. Connect power supply to DC socket and turn on unit from power switch
6. Adjust aerial tune knob for maximum power on output power display



Advanced setup and troubleshooting

Internally, there are several links for adjustment to aerial matching across the frequency spectrum. These add additional capacitance at the lower end, a table shown further below explains the settings required. Remove top cover to gain access. Also, there are several selector links, one is for tappings on the output coil (toroid) which is used for better aerial matching. At different frequencies, 2 other sets of links are used to put fixed capacitors across the tuning capacitor in order to maximise the matching, (links X and Y) use the link to select a lower inductance for improved matching. A better match may be achieved by moving this link. Experimentation is required here.

A longer aerial wire can be used with the transmitter and will give a better range. Excellent results have been obtained using a single long wire of approximately 18 metres length as shown in the diagram. The aerial is essentially the length of the back garden, using

insulators that radio hams use. Roof top is the end of the wire, suspended via a tree at the other end. Also, the use of a good Earth helps with signal efficiency and distance. A copper stake in the ground is a good start. Search the Internet for further advice.

NOTE – DO NOT USE COAXIAL CABLE ON THE AERIAL FEED. It is high impedance and will load the output down and produce little output. Use separate wires for Aerial and Earth! The link is located on the main circuit board by the circular toroid. There are 3 selections, 60 turns, 80 turns and 100 turns. Select '1-3' for minimum (60 turns tapped) inductance, '2-3' for mid-range inductance (80 turns) and NO LINK for maximum inductance (100 turns). The tap gives less inductance for much better match to the longer aerial. Maximise the signal level with the tuning control, whilst observing the signal level LED display. Or even better is the use of a Field Strength Meter, which are readily available on eBay.
Note- if link isn't required, just leave it on any pin sideways and therefore not linked.

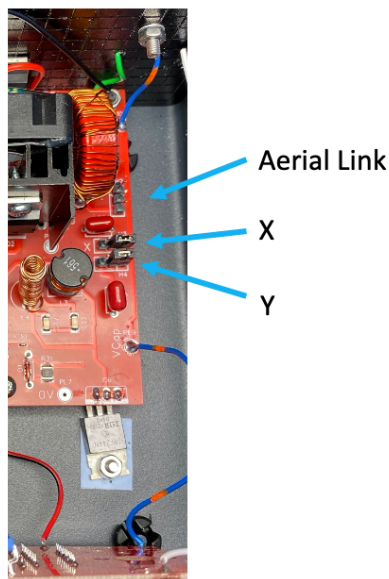

X and Y are shown in OFF position.
Move link to left for connection in circuit.

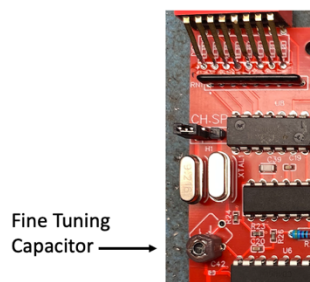

It is possible to fine-tune the operating frequency by adjusting VC1 on the main circuit board. (see pic) This adjustment is for alignment of the output frequency and is pre-set prior to shipping.

Aerial Matching

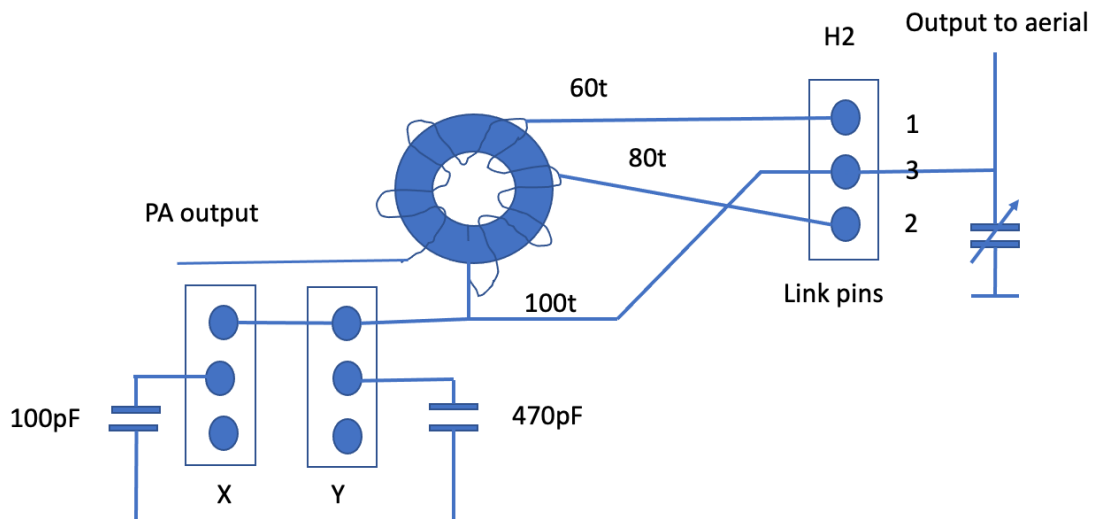

Various link options to output section

540 – 700KHz		Link Y
700 – 840KHz	Link X	
840 – 1000KHz	Link X	
1000 – 1800KHz	No Link	

Hum on audio

If you experience hum (normally most noticeable the further the receiver is away from the transmitter) then reposition transmitting antenna or receiver.

When used indoors the wiring running through the house picks up the signal causing “hum spots”.

Repositioning to a ‘non hum’ area will cure this, or use the ‘Hum Cancel’ trimmer to null out the noise. This injects a very small 30Hz -70Hz signal into the audio chain. VR1 is 30Hz fully anticlockwise, 70Hz fully clockwise. 50Hz is about ¾ around in clockwise position.

Bluetooth connectivity

A Bluetooth module can be fitted at nominal extra cost. To use this, make sure that the wired (phono) cables are removed from the rear sockets, as this loads the audio signal down.

On your Bluetooth device, search for JH-BT for connection. It auto connects.

Please note that without any audio signal the expander in the transmitter increases the noise from the Bluetooth module. But this soon disappears when audio is present.

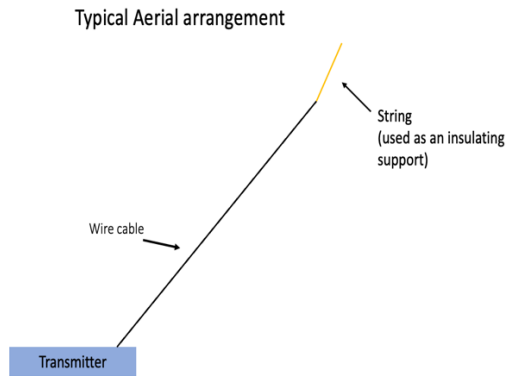

Arrangement using supplied Aerial

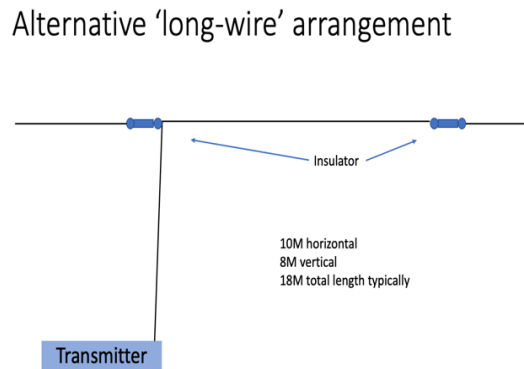

Alternative arrangement using long-wire

Frequency setting

Setting frequency using dip switches

There are 2 versions, EU or USA spacing as controlled by different crystals to obtain either 9KHz or 10KHz channel spacing. EU channels are in Blue, USA in Red in the tables.

At the rear of the transmitter there are a set of dip switched numbered 1 to 8.

Using the frequency table set the switches to the desired frequency.

For example, if your desired frequency is 1530Khz (1700KHz for USA crystal), look it up in the table and you will see its binary setting to the left.

As we can see the binary position is: 1 0 1 0 1 0 0 1

1530 1700 10101001

The switch positions are up for 0 and down for 1. So therefore, starting from the left-most switch and working our way to the right we get the following:

Binary number	1	0	1	0	1	0	0	1
Switch position	on	off	on	off	on	off	off	on

It looks like this:



On the rear, the DIP switches determine the frequency.

Binary switch positions

Frequency Setting on S1 (kHz) Blue=UK/EU. Red=USA

Pre-set	S1	S2	S3	S4	S5	S6	S7	S8
UK-EU	USA							
477	540	00110101	594	660	01000001	702	780	01001101
495	550	00110110	603	670	01000010	711	790	01001110
504	560	00110111	612	680	01000011	720	800	01001111
513	570	00111000	621	690	01000100	729	810	01010000
522	580	00111001	630	700	01000101	738	820	01010001
531	590	00111010	639	710	01000110	747	830	01010010
540	600	00111011	648	720	01000111	756	840	01010011
549	610	00111100	657	730	01001000	765	850	01011100
558	620	00111101	666	740	01001001	774	860	01010101
567	630	00111110	675	750	01001010	783	870	01010110
576	640	00111111	684	760	01001011	792	880	01010111
585	650	01000000	693	770	01001100	801	890	01011000
810	900	01011001	918	1020	01100101	1026	1140	01110001
819	910	01011010	927	1030	01100110	1035	1150	01110010
828	920	01011011	936	1040	01100111	1044	1160	01110011
837	930	01011100	945	1050	01101000	1053	1170	01110100
846	940	01011101	954	1060	01101001	1062	1180	01110101
855	950	01011110	963	1070	01101010	1071	1190	01110110
864	960	01011111	972	1080	01101011	1080	1200	01110111
873	970	01100000	981	1090	01101100	1089	1210	01111000
882	980	01100001	990	1100	01101101	1098	1220	01111001
891	990	01100010	999	1110	01101110	1107	1230	01111010
900	1000	01100011	1008	1120	01101111	1116	1240	01111011

909	1010	01100100	1017	1130	01110000	1125	1250	01111100
1134	1260	01111101	1242	1380	10001001	1350	1500	10010101
1143	1270	01111110	1251	1390	10001010	1359	1510	10010110
1152	1280	01111111	1260	1400	10001011	1368	1520	10010111
1161	1290	10000000	1269	1410	10001100	1377	1530	10011000
1170	1300	10000001	1278	1420	10001101	1386	1540	10011001
1179	1310	10000010	1287	1430	10001110	1395	1550	10011010
1188	1320	10000011	1296	1440	10011111	1404	1560	10011011
1197	1330	10000100	1305	1450	10010000	1413	1570	10011100
1206	1340	10000101	1314	1460	10010001	1422	1580	10011101
1215	1350	10000110	1323	1470	10010010	1431	1590	10011110
1224	1360	10000111	1332	1480	10010011	1440	1600	11001111
1233	1370	10001000	1341	1490	10010100	1449	1610	10100000
1458	1620	10100001	1521	1690	10101000	1584	1760	10111111
1467	1630	10100010	1530	1700	10101001	1593	1770	10110000
1476	1640	10100011	1539	1710	10101010	1602	1780	10110001
1485	1650	10100100	1548	1720	10101011	1611	1790	10110010
1494	1660	10100101	1557	1730	10101100	1620	1800	10110011
1503	1670	10100110	1566	1740	10101101	1629		10110100
1512	1680	10100111	1575	1750	10101110	1638		10110101

Adjustment and alignment.

There is no PLL alignment setting other than a 'fine tune' trim using trimmer capacitor VC1 on the main circuit board. This is the brown component by the crystal. A jeweller's screwdriver is used to adjust this. It is possible to 'zero-beat' with other stations on channel.

RF Drive.

The pre-set VR3, labelled DRIVE is used to adjust the signal drive to the output FET.

Observing the output signal 'Bargraph' display, adjust the potentiometer to achieve maximum signal output. Or use an oscilloscope to observe drain and gate voltages on the output FET. Adjusting this preset will help to maximise the output across the band.

Audio Level

Adjust preset VR2 for maximum modulation, ideally using an oscilloscope for maximum (but not over) modulation depth. Without breaking carrier. (solid line at 0%)

Hum cancel

In an attempt to remove hum from the audio signal, if there is any, this is accomplished by adjustment of VR1. This is best done whilst operational. It introduces a low level 30 -70 Hz signal into the drive. The idea is to cancel-out hum on the received audio signal.

Resetting the Frequency display

The Programmed Chip can get swamped with RF and may make it display incorrectly. (this is very uncommon but has been observed)

A micro switch (the black push button) is fitted to the display board to allow the display to be reset. Press the switch once to enter setup. Press through the stages, so that you select 'No PS' (does not enter 'sleep mode'), Zero (offset) press and hold until it flashes to set this and press to hold for exit to save setup.

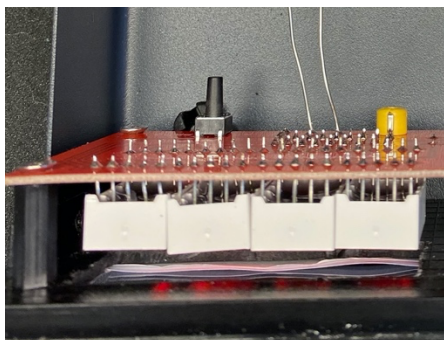

RF level monitor

The Bargraph is a visual representation of carrier level and Modulation. The signal is detected by the mini-RF sniffer aerial inside and this converts to the LED scale. The sensitivity of this is adjusted by VR4 on the front panel PCB and by moving the sniffer nearby to the RF Capacitor conductor between the main board and the front panel board. (the sniffer aerial is connected only at the display board and is left floating near to the coil)

Aerial Matching

As described above, the desired operating frequency is adjusted to suit the aerial by using the linking contacts in the output section, plus the links for additional capacitance. Use the LED tuning indicator for maximum output.

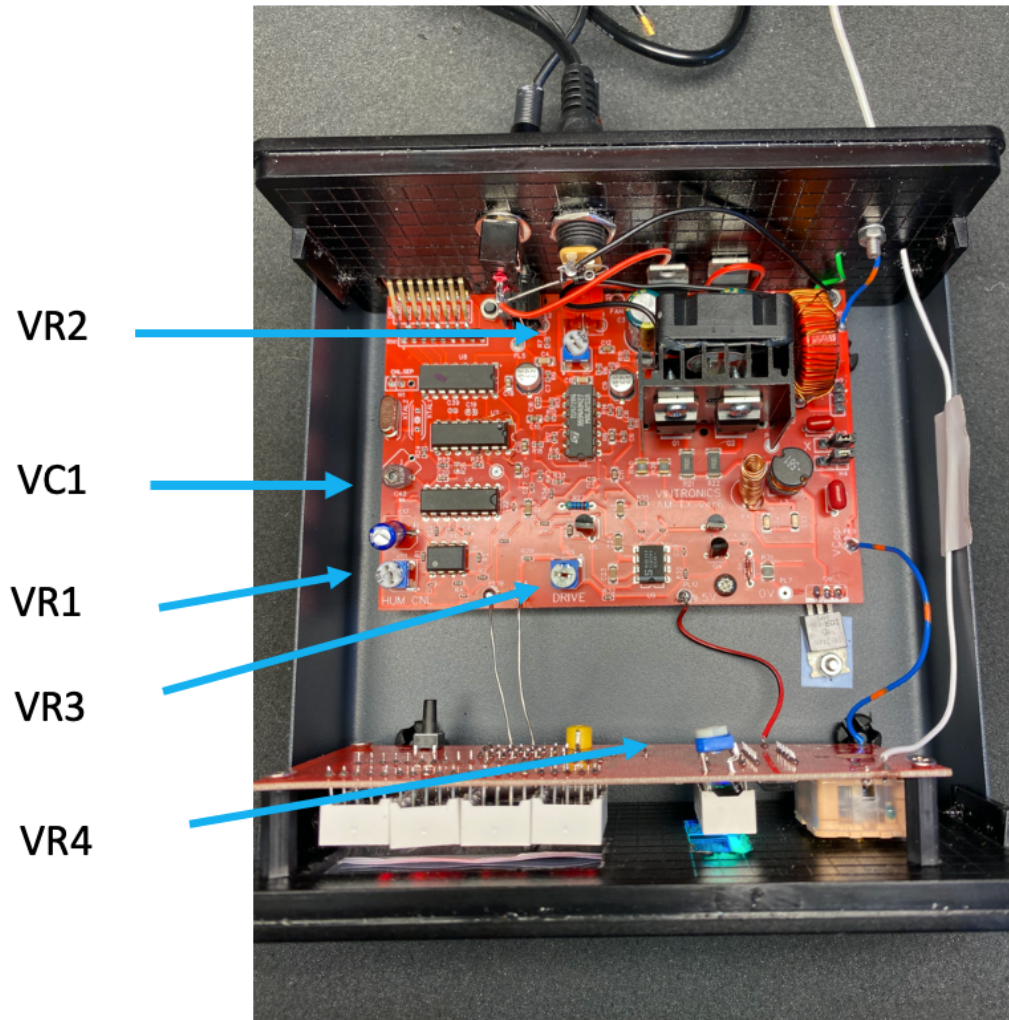

NB. Early circuit boards do not have the 'X' and 'Y' capacitor links. Instead, external capacitors are fitted across the Aerial and Earth terminal block on the rear.

Technical Specifications

1 Watt Unit

Size - 150mm wide, 150mm depth, 75mm high

Weight. - 0.9Kg

Power requirement - DC 12V @ 600mA max

Audio input – RCA Phono sockets, left and right audio between 75mV and 775mV RMS

Audio Bandwidth (+ –3dB) - 80Hz to 6KHz

Modulation level – up to 100%

RF Output level – 1 Watt (or more depending on Aerial Match)

RF Output Capacitor – 370pF variable

RF connection – screw terminal for signal and earth connection

Display -

Signal level – 10 segment Bar-Graph multi-colour LED

Frequency – 4 7-segment LED display

Ventilation – passive convection

4 Watt Unit

Size - 150mm wide, 150mm depth, 75mm high

Weight. - 1Kg

Power requirement - DC 17-18 V @ 1A max

Audio input – RCA Phono sockets, left and right audio between 75mV and 775mV RMS

Audio Bandwidth (+ –3dB) - 80Hz to 6KHz

Modulation level – up to 100%

RF Output level – 3 - 5 Watts (dependant on Aerial Match)

RF Output Capacitor – 400pF variable

RF connection – screw terminal for signal and earth connection

Display -

Signal level – 10 segment Bar-Graph multi-colour LED

Frequency – 4 7-segment LED display

Ventilation - Cooling fan forced airflow